

 master lifts



It's not just a lift, it's a Lifestyle



Company Profile



Dear Customer,

Welcome to Master Lifts.

Master Lifts has a rich history of over 20 years in the industry as an Australian owned and operated business and during this time has sold, installed and serviced over 9000 lifts across Australia.

Master Lifts has the unique advantage of manufacturing lifts in Australia and importing lifts from international suppliers, where we have established trading relationships with recognised suppliers for their innovation, cutting edge design, quality and value for money.

Some of our partnerships with suppliers have existed and flourished for more than 19 years which gives us, and you, our customer, the security and confidence of supply.

Master Lifts is recognised by industry and government authorities as the leader in providing building access solutions in residential and commercial applications where other companies can't provide the personalised solutions.

Master Lifts now releases our new range of residential lifestyle lifts specifically designed for the Australian market, these can be incorporated into the stylish and contemporary design of your new home or they can be personalised and retrofitted into existing homes whilst retaining the style and appeal of the home.

The Future is now!

Master Lifts is proud to release the Go Green, Go Gearless traction lift.

Machine Roomless Lift (MRL) is such an advanced integration of technology and style, it is light weight, provides a very smooth ride and is ecologically friendly, with low energy consumption and whisper quiet travel.

The stylish Italian design combines safety and flexibility, to be personalised to meet your individual needs. Additionally, the Lifestyle Lift satisfies the most challenging and demanding of architectural requirements.

With our history, new products, continuously improved technology and our unrivalled customer service, we are able to deliver a lift solution for any environment.

Alan Arnold

Managing Director



AUSTRALIAN OWNED



“We are proud to offer you our *Lifestyle Lift*, together with quality materials, smooth modern design and the ability to cater to your individual needs and requirements”

The Lifestyle Lift has the flexibility to satisfy the most demanding specifications catering to individual needs. Available in many Australian designs and colours! The Lifestyle lift is both reliable and safe.

Featuring an integrated emergency battery lowering system, automatic return to lowest floor feature and full height light beam car safety entrance protection included as standard features with each design.

Our manufacturing is completed in Italy by Eltec, to the highest quality and safety standards, giving you total peace of mind.

Together with Master Lifts, Eltec is an effective and professional partner in the design and installation, of tailor made solutions in the lift and elevator field: from the simple aesthetic personalisation to the use of fine materials for finishing, and the development of the most contemporary products, that are completely custom in dimensions, design and technology.



Elsa Door

The Elsa, is a single wing door, manual or automatic opening. Featuring double speed hydraulic door close functionality, the Lifestyle Lift also comes in a selection of aluminium frame colours, and glass doors, that are all available as part of the standard package. The new 'Mekano' finishing is also now available.

With choices of a single, or doubled winged doors in either semi-automatic and automatic function, we can even turn a manual door to automatic by a simple motor installation which can be hidden inside the frame of the lift.

The features are endless with the new Lifestyle Lift!



“Solar brightness, invisible technology”



Ultra Smooth...

Hinges are completely hidden inside the frame!



The Elettra Door is a double winged door fitted with glass panelling, and comes in a wide range of finishes. With automatic 'opening and closing' and motors hidden inside the frame for a professional clean finish, the smooth lines are endless! Along with the standard colourings the new 'Mekano' finish is now available for the Elettra design, giving a metalized and micaceous effect.

Locking devices both electrical and mechanical are installed into the lift to ensure that it is impossible for the lift to travel away from the landing when the door is not closed, and the mechanical locking devices ensures the lift doors wont open until the lift reaches floor level. Maximum safety features, are paramount in the Lifestyle Lift.

The Elsa and Elettra doors are available, in a large range of dimensions.

"New motor protection safety system inside"

Free Standing

Combining the sophisticated Italian designs, with modern trends and environment friendly parts options, the Lifestyle Lift stands out from the other lifts in the competitive market today.

Completely made of aluminium, this is a self supporting lift shaft by Eltec. The structure has been designed for appeal and elegance, with no obstruction to the clean smooth design. The finish of the panelling can be both external or internal, and a wide variety of colour choices for safety

glass, wooden or insulating panels. The structure itself also, has a wide range of colour and anodization choices available. Master Lifts, success over the past 20 years has been built up by repeatedly satisfying our customers, providing exceptional service and ensuring that the final product meets all client and regulatory expectations.

Our team of experienced staff ensure that every step of your lifts installation is of the highest quality and to product specification and compliance.

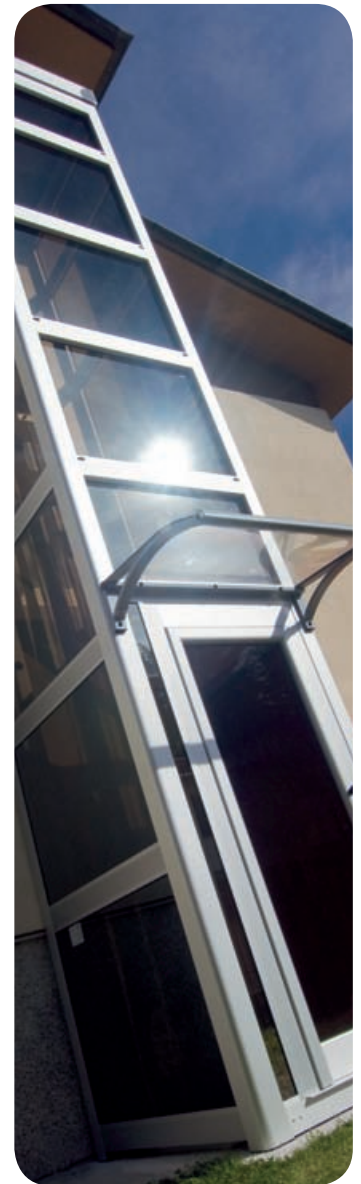

Style has never looked this good!

Technical Aspects

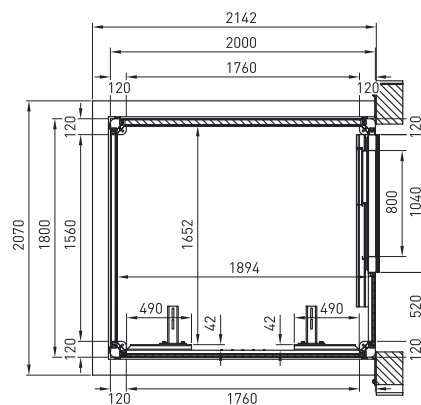
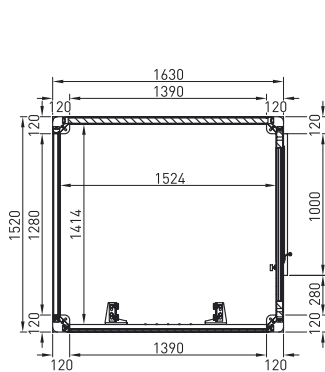
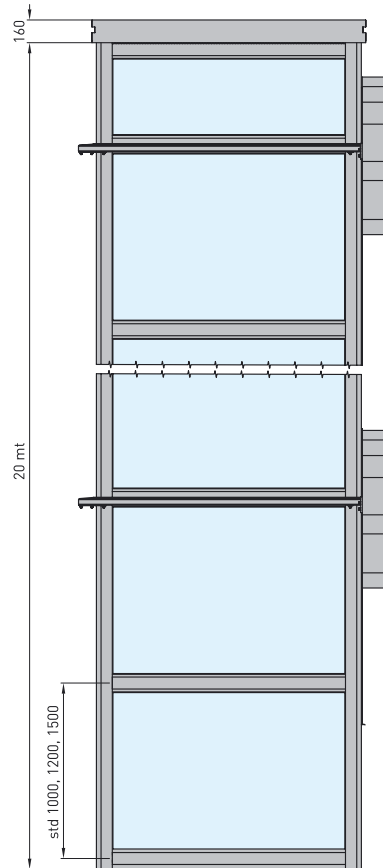
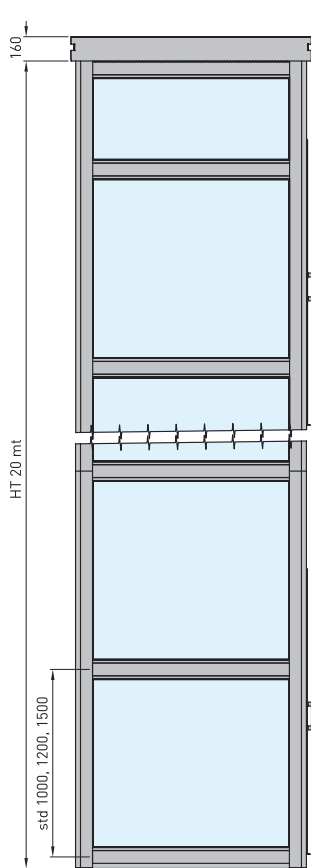

Available in many design variations to cater for individual needs, The Lifestyle Lift also offers a Traction System, which is an eco-friendly option with electric gearless motor technology for optimum energy reduction. Specifically designed for the private home, its designed to fit small spaces, is smooth and quiet and comprises fully automatic control.

Quality.

Reliability.

Safety.

Innovation.

Make it your *Lifestyle.*

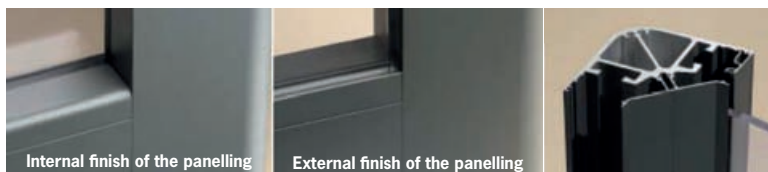

Internal finish of the panelling

External finish of the panelling

For indoor and outdoors.

Technical Specifications

Safety is the key element in the technical aspects of the Lifestyle Lift design. The following points outline the features Lifestyle Lift contains ensuring a safe travel environment with or without the resource of electricity.

- **Automatic emergency lowering system**, allows the lift to lower to the base level, and unlock the door in an event of power failure, running on backup battery supply.
- **Emergency lighting**, in a power failure, emergency lights turn on and the lower level button lights up, indicating to press and return to lower level for exit.
- **Over speed sensing**, standard with lift installation, a sensor is installed as a safety measure to ensure the lift doesn't 'over speed'.
- **Electrical locks**, these locks make it impossible for the lift to start elevation if the doors are not closed.
- **Mechanical locks**, this function in turn with the electrical locks, wont allow the doors to open if the lift is not at floor level.
- **Key Switch**, is a lock in the car accessible to authorised people if needed to both lock and unlock the lift. Both turning it off and on through the operating panel.
- **A telephone** is provided inside the lift, incase of an emergency. Emergency services telephone number is programmed into the system and, is available 24 hours a day 7 days a week.

Technical Specifications

Load	250/300/360 kg
No. of people	3/4/5
Stops	5
Max. Speed	0.3 m/sec approx.
Max. Travel	16500 mm
Engine power	1,5/1,8 kW 230 V Single Phase
Min. Head room	2530/2630
Pit	100 mm
Cabin height	2015/2115
Unit cabinet size	300 x 600 x 800/1200

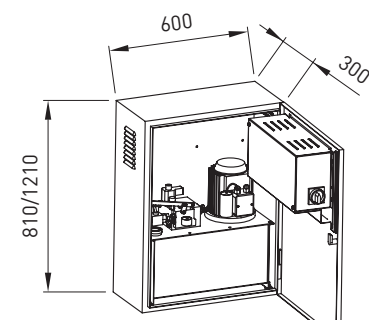
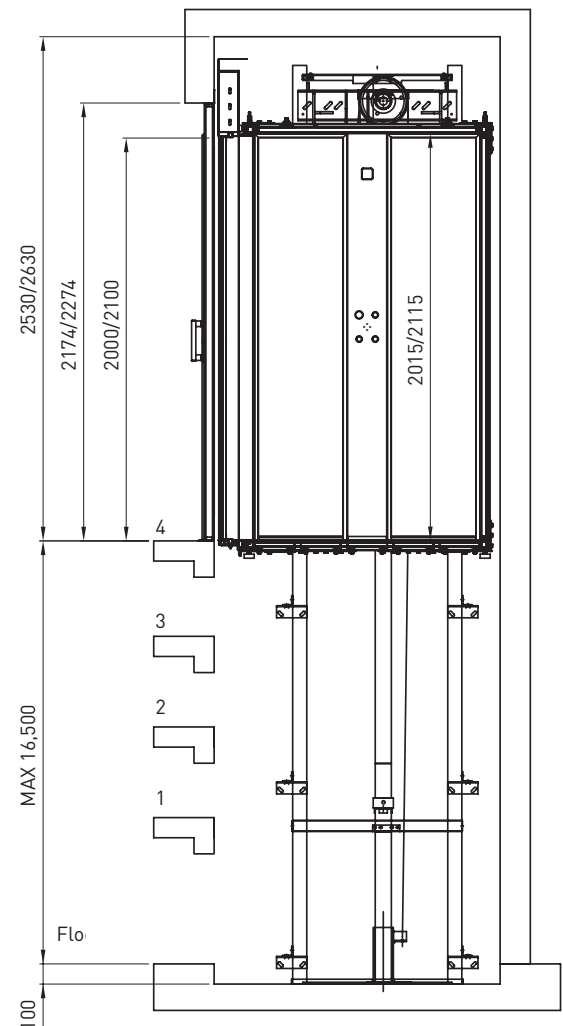
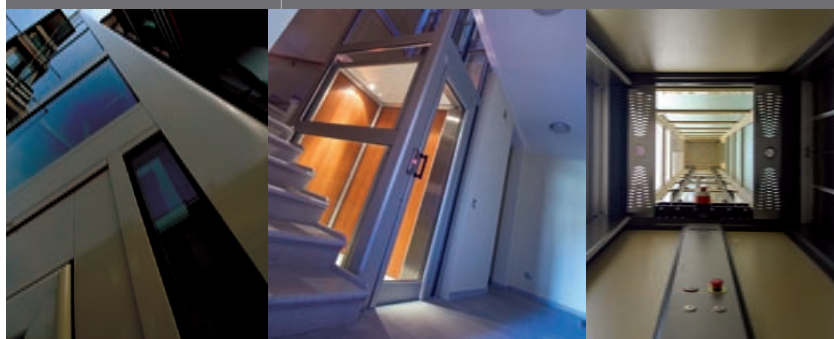

Automatic Control*

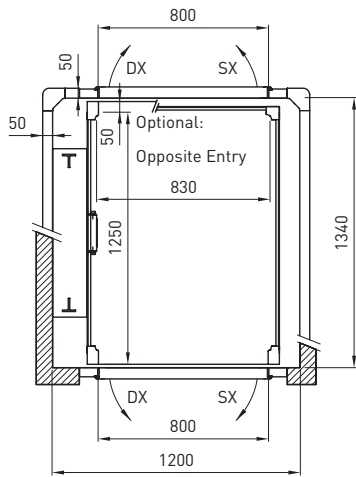

Cabin door side A

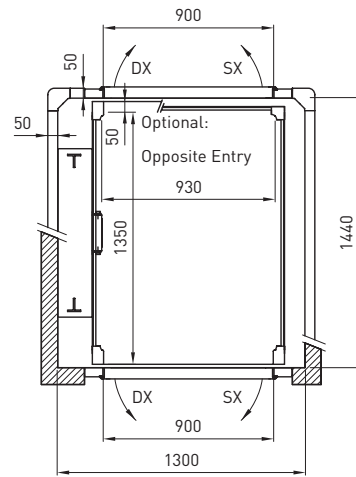

Cabin door side B

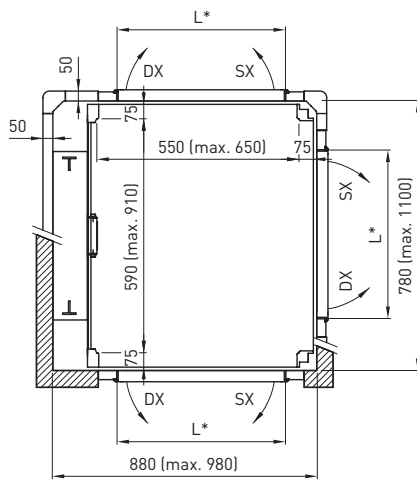

Cabin door side C

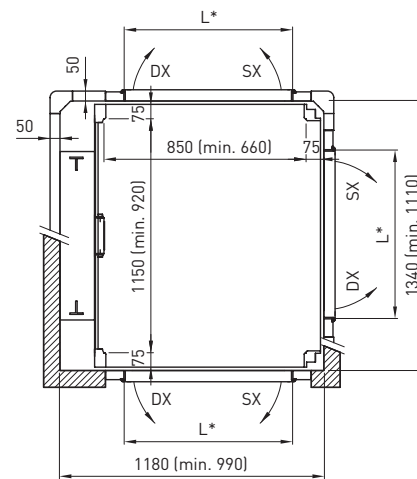

Cabin door side A,C

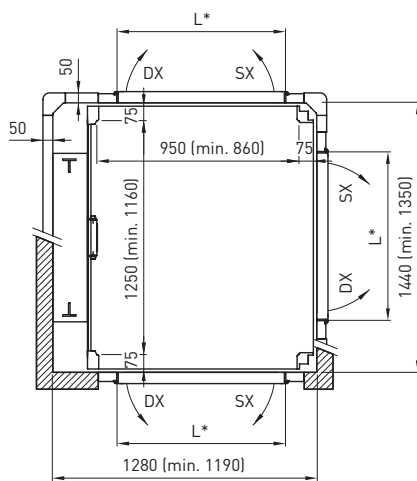

Cabin door side A,B

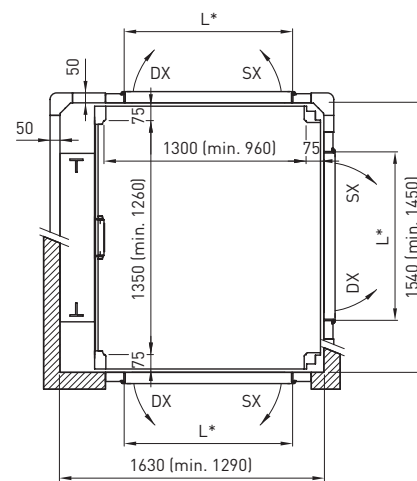

Cabin door side B,C

* When fitted with full height photo electric light barriers.

GO GREEN... GO GEARLESS

Environmentally friendly **Gearless Traction** lift.



THE FUTURE IS NOW!

The home lift revolution starts with the **Gearless Traction Lift**.

With great energy conservation features, using only a 450 watt motor, energy consumption is only required to raise the lift, using no more than a small electrical appliance in the home, making running costs extremely low.

Other features with the Gearless Traction are;

- Auto-off lighting, LED down lights, lasting 50 times longer than a standard halogen light, with 80% energy reduction.
- The car is programmed to park at its final destination, to save on any unnecessary operation and travel of the car.
- Class A energy efficient, with the European Union energy label, helping to reduce your overall domestic environmental footprint and impact.
- NYLON SHEAVE WHEEL technology, holds the nylon steel coated cables. Avoiding the steel on steel wear and noise.

An energy saving solution that helps the environment!

Technical Specifications

Load	450kg
No. of people	6
Stops	8
Max. Speed	0.3 m/sec approx.
Max. Travel	20,000 mm
Engine power	450 w Single Phase
Min. Head room	2490/2590
Pit	260 mm
Cabin height	2000/2100
Control cabinet	Integrated in head room

- **International product**
- **Highest quality of finishes**
- **Catering to individual home requirements**
- **Designed to fit in the smallest of places.**
- **Many safety features**
- **Fully automatic**
- **Smooth and quiet travel**
- **Oil free**



Gearless Traction Lift Technical Aspects

Self supporting shaft

Shaft by others

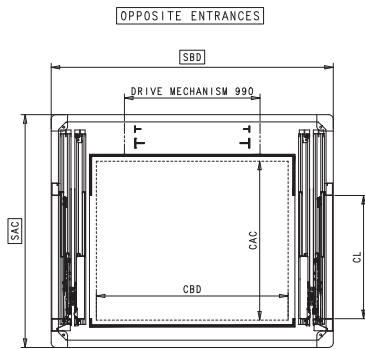

	MAX	MIN
SBD	2060	1540
SAC	1700	1350
CBD	1400	800
CAC	1160	1010
CL	900 MAX	800 MAX

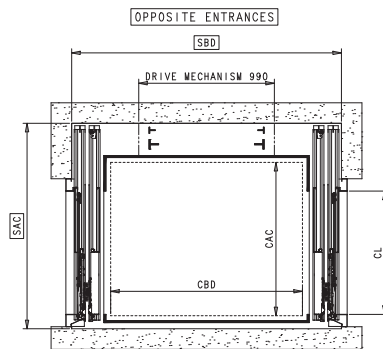

	MAX	MIN
SBD	1970	1450
SAC	1500	1350
CBD	1400	800
CAC	1120	970
CL	900 MAX	800 MAX

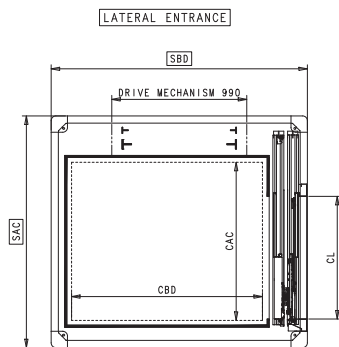

	MAX	MIN
SBD	1880	1540
SAC	1700	1550
CBD	1400	1060
CAC	1160	1010
CL	900 MAX	800 MAX

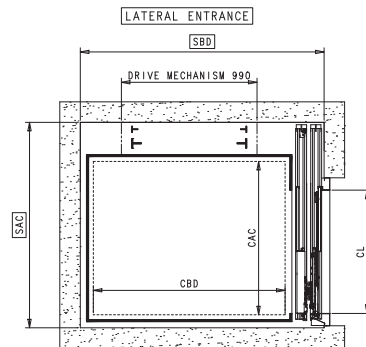

	MAX	MIN
SBD	1780	1540
SAC	1500	1540
CBD	1400	1160
CAC	1120	970
CL	900 MAX	800 MAX

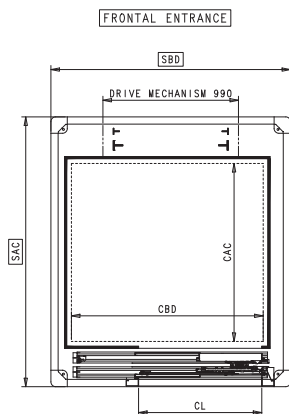

	MAX	MIN
SBD	1750	1550
SAC	1970	1420
CBD	1400	1150
CAC	1300	750
CL	900 MAX	800 MAX

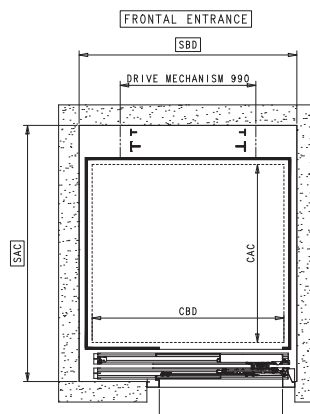

	MAX	MIN
SBD	1590	1350
SAC	1870	1320
CBD	1400	1160
CAC	1300	750
CL	900 MAX	800 MAX

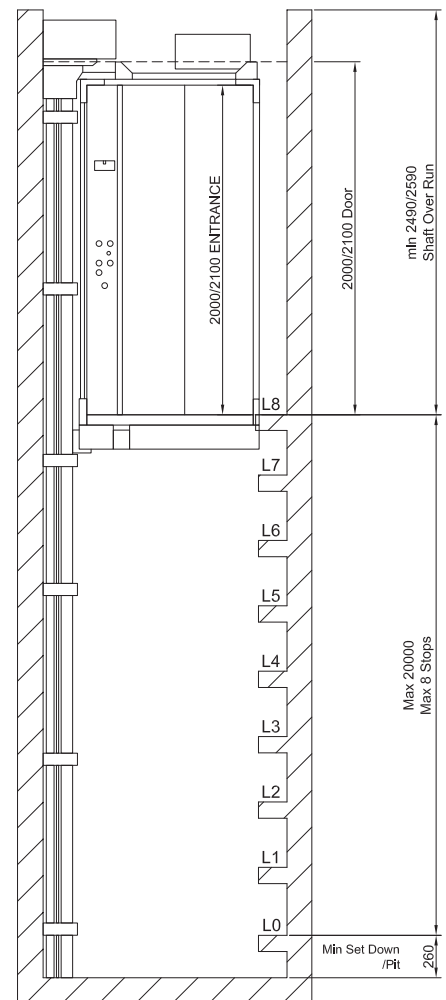



It's not just a lift, it's a Lifestyle



DISCLAIMER: No part of this document is to be reproduced or used in any manner without the written permission of Master Lifts Group Pty Ltd. All photography, illustrations and specifications contained in this brochure are based on the latest information available at the time of the publication release date. Master Lifts reserves the right to make changes to both technical aspects, materials, equipment, warranties, colours and variables at any time without public notice. Imagery is for visual purposes only, and technical information should be confirmed with sales staff to ensure no recent changes or alterations have been made prior to measuring up your areas for installation.

 **master lifts**

Master Lifts Group Pty Ltd

☎ 1300 454 387

www.masterlifts.com.au

0 6 2 0 1 2